

## «Easy close» all-metal angle valve with manual actuator

**Series 541**  
**DN 16 – 63 mm (I. D. 5/8" – 2 1/2")**

This manual is valid for the following product ordering numbers:

**54124- . E02 - ....**

**54132- . E02 - ....**

**54136- . E02 - ....**

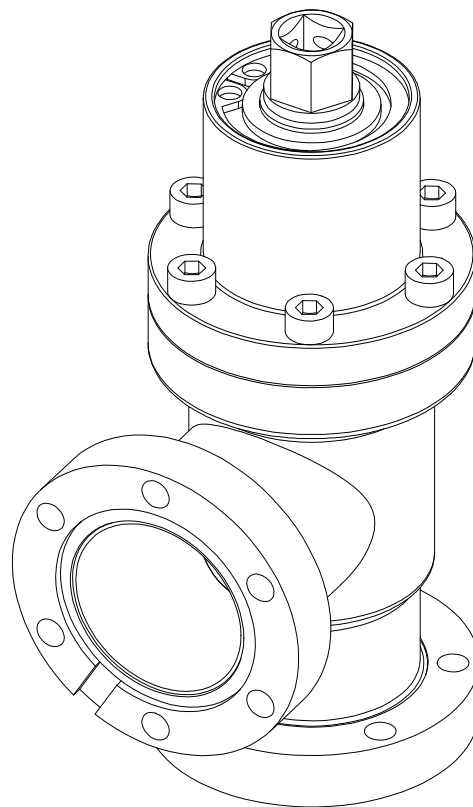

Sample picture

## Imprint

Manufacturer VAT Vakuumventile AG, CH-9469 Haag, Switzerland

Website: [www.vatvalve.com](http://www.vatvalve.com)  
Phone: +41 81 771 61 61  
Fax: +41 81 771 48 30  
Email: [CH@vatvalve.com](mailto:CH@vatvalve.com)

Publisher VAT Vakuumventile AG, CH-9469 Haag, Switzerland

Editor VAT Vakuumventile AG, CH-9469 Haag, Switzerland

Print VAT Vakuumventile AG, CH-9469 Haag, Switzerland

Copyright © VAT Vakuumventile AG 2015

No part of these instructions may be reproduced in any way (photocopies, microfilms or any other reproduction processes) nor may it be manipulated with electronic systems, duplicated or distributed without written permission from VAT. Offenders are liable to pay damages.

The original VAT firmware and updated state of the art versions of the VAT firmware are intended for use with VAT products. The VAT firmware contains a limited, time unlimited user license. The VAT firmware may not be used for purposes other than those intended nor is it permitted to make copies of the VAT firmware. In particular, it is strictly forbidden to give copies of the VAT firmware to other people.

The use of trade names, brand names, trademarks, etc. in these Instructions does not entitle third parties to consider these names to be unprotected and to use them freely. This is in accordance with the meaning of the laws and acts covering brand names and trademarks.

## Contents

<b>1</b>	<b>Description of product.....</b>	<b>4</b>
1.1	Identification of product.....	4
1.2	Use of product.....	4
1.3	Related documents.....	4
1.4	Important information.....	4
1.5	Technical data.....	4
<b>2</b>	<b>Safety .....</b>	<b>5</b>
2.1	Compulsory reading material.....	5
2.2	Danger levels .....	5
2.3	Personnel qualifications.....	6
2.4	Safety labels.....	6
<b>3</b>	<b>Design and Function.....</b>	<b>7</b>
3.1	Design.....	7
3.2	Function .....	8
<b>4</b>	<b>Installation .....</b>	<b>9</b>
4.1	Unpacking .....	9
4.2	Installation into the system.....	10
4.2.1	Preparation for installation .....	10
4.2.2	Mounting to the system.....	12
<b>5</b>	<b>Operation .....</b>	<b>13</b>
5.1	Normal operation.....	13
5.2	Operation under increased temperature.....	13
5.3	Trouble shooting.....	14
<b>6</b>	<b>Maintenance .....</b>	<b>15</b>
6.1	Maintenance intervals.....	15
<b>7</b>	<b>Repairs .....</b>	<b>16</b>
7.1	Replacement of dynamic seal – FLEX VATRING .....	17
<b>8</b>	<b>Dismounting and Storage.....</b>	<b>21</b>
8.1	Dismounting .....	21
8.2	Storage .....	21
<b>9</b>	<b>Packaging and Transport .....</b>	<b>22</b>
9.1	Packaging .....	23
9.2	Transport.....	23
<b>10</b>	<b>Disposal .....</b>	<b>24</b>
<b>11</b>	<b>Spare parts .....</b>	<b>25</b>

# 1 Description of product

## 1.1 Identification of product

The fabrication number is engraved directly on the product.



XXXXX-XXXX-XXXX/XXXX ← Fabrication number

Made in Austria

## 1.2 Use of product

Use product for clean and dry vacuum applications only. Other applications are only allowed with the written permission of VAT. Suitable for XHV applications.

## 1.3 Related documents

- Product data sheet
- Dimensional drawing

## 1.4 Important information



This symbol points to a very important statement that requires particular attention.

### Example:



VAT disclaims any liability for damages resulting from inappropriate packaging.

## 1.5 Technical data

See product data sheet and dimensional drawing.

Weights of standard valves:

DN 16: 0.4 kg  
DN 40: 1.9 kg  
DN 63: 6 kg

Weight of special valves, see product data sheet.

## 2 Safety

### 2.1 Compulsory reading material

Read this chapter prior to performing any work with or on the product. It contains important information that is significant for your own personal safety. This chapter must have been read and understood by all persons who perform any kind of work with or on the product during any stage of its serviceable life.

	NOTICE
	<p><b>Lack of knowledge</b> Failing to read this manual may result in property damage. Firstly, read manual.</p>





These Installation, Operating & Maintenance Instructions are an integral part of a comprehensive documentation belonging to a complete technical system. They must be stored together with the other documentation and accessible for anybody who is authorized to work with the system at any time.

### 2.2 Danger levels

	⚠ DANGER
	<p><b>High risk</b> Indicates a hazardous situation which, if not avoided, will result in death or serious injury.</p>

	⚠ WARNING
	<p><b>Medium risk</b> Indicates a hazardous situation which, if not avoided, could result in death or serious injury.</p>

	⚠ CAUTION
	<p><b>Low risk</b> Indicates a hazardous situation which, if not avoided, may result in minor or moderate injury.</p>

	NOTICE
	<p><b>Command</b> Indicates a hazardous situation which, if not avoided, may result in property damage.</p>

### 2.3 Personnel qualifications

	<b>WARNING</b>
	<p><b>Unqualified personnel</b>                  Inappropriate handling may cause serious injury or property damage.                  Only qualified personnel are allowed to carry out the described work.</p>

### 2.4 Safety labels

Label	Part No.	Location on valve
	T-9001-155	On protective covers of flanges

Table 2-1

### 3 Design and Function

#### 3.1 Design

With manual actuator:  
Type 541 ... - . E02 - ....

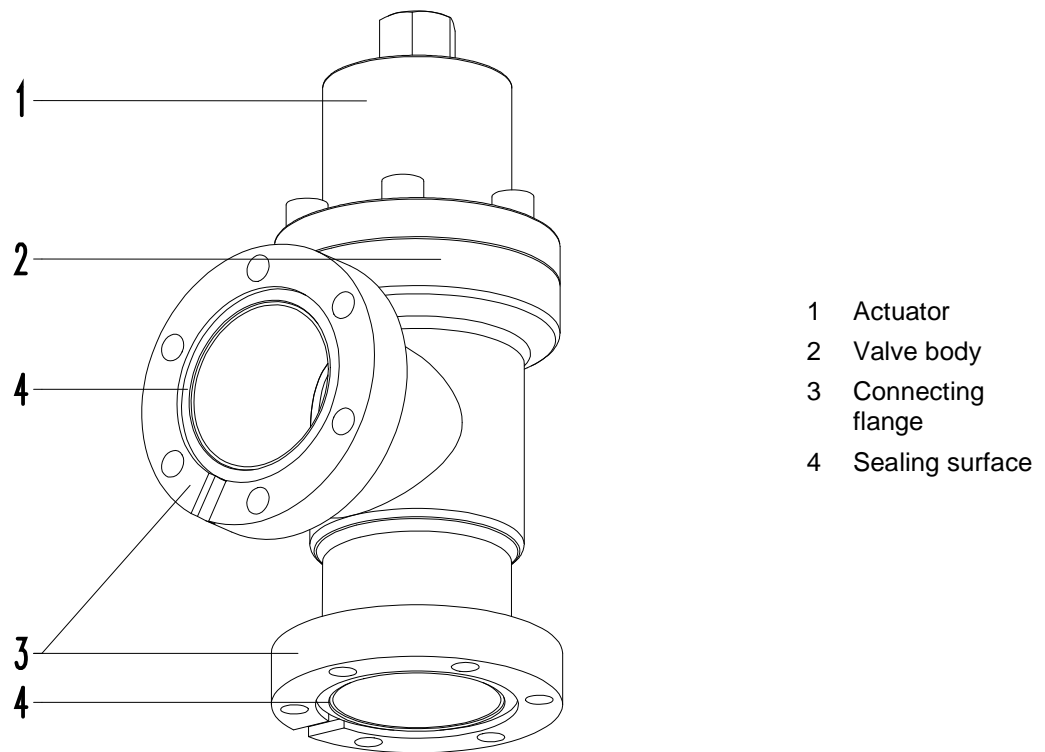

Figure 3-1

### 3.2 Function

Valve is closed and opened manually.

Closing: Turn hexagon head or inner square clockwise to its stop. For moving the plate only a small closing torque is required. Then a second step with a steadily increasing torque (sealing the valve) will follow until the stop is reached.

Opening: Turn hexagon head counter clockwise to its stop. The valve is completely open when the stop is reached.

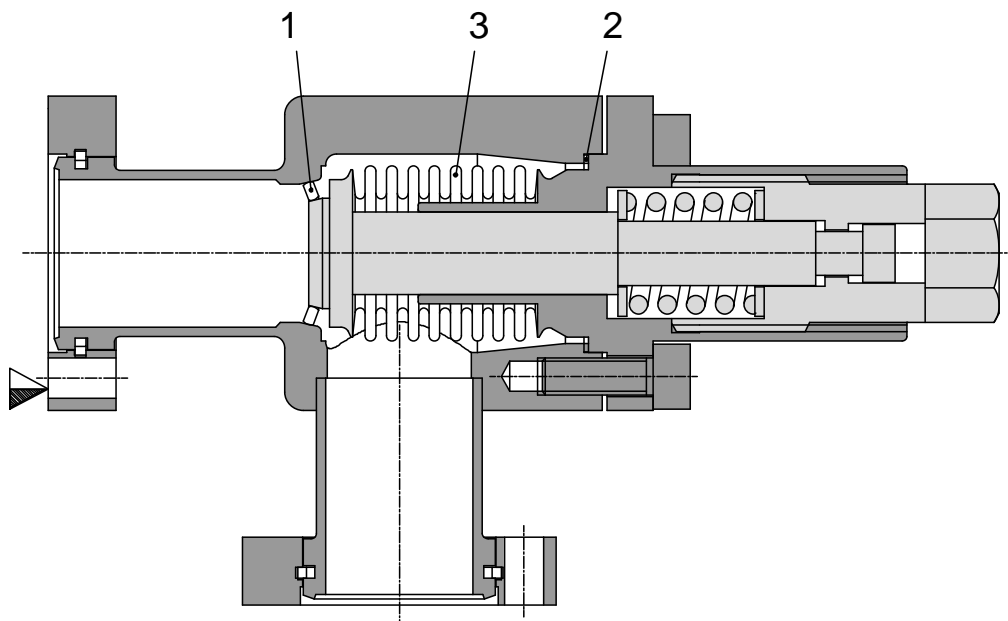



Figure 3-2

- 1 FLEX VATRING
- 2 Bonnet seal
- 3 Bellows
- ▼ Valve seat side



## 4 Installation

	<b>WARNING</b>
	<p><b>Unqualified personnel</b> Inappropriate handling may cause serious injury or property damage. Only qualified personnel are allowed to carry out the described work.</p>

### 4.1 Unpacking



- Make sure that the supplied products are in accordance with your order.
- Inspect the quality of the supplied products visually. If it does not meet your requirements, please contact VAT immediately.
- Store the original packaging material. It may be useful if products must be returned to VAT.





Don't open the plastic bag before mounting into the system.

	<b>NOTICE</b>
	<p><b>Sensitive product</b> Valve parts may get damaged.</p> <ul style="list-style-type: none"><li>– When lifting the valve, pay attention that the valve does not touch any solid objects.</li><li>– Lift valve carefully and put it down on a clean surface or mount it to a clean system.</li></ul>

Weight of standard valves; see chapter «1.5 Technical data».

## 4.2 Installation into the system

	NOTICE
	<p><b>Contamination</b></p> <p>Product may get contaminated. Always wear cleanroom gloves when handling the product.</p>

	NOTICE
	<p><b>Force effect from other components of the system</b></p> <p>Valve body may get deformed and/or malfunctions may occur.</p> <ul style="list-style-type: none"> <li>– Do not use valve to support other components.</li> <li>– Make sure that forces from other components do not impair the valve; use bellows sections, for instance.</li> </ul>

### 4.2.1 Preparation for installation

	⚠ WARNING
	<p><b>Danger of injury in case of insufficient skills</b></p> <p>Inappropriate handling may cause serious injury or property damage. Make sure that the valve does not topple or fall down while removing the protective covers from the flanges.</p>

	NOTICE
	<p><b>Sensitive product</b></p> <p>Valve parts may get damaged. When removing the protective covers from the flanges, be careful to avoid damage to the valve.</p>

1. Remove plastic bag.
2. Remove protective covers (1); see «Figure 4-1».

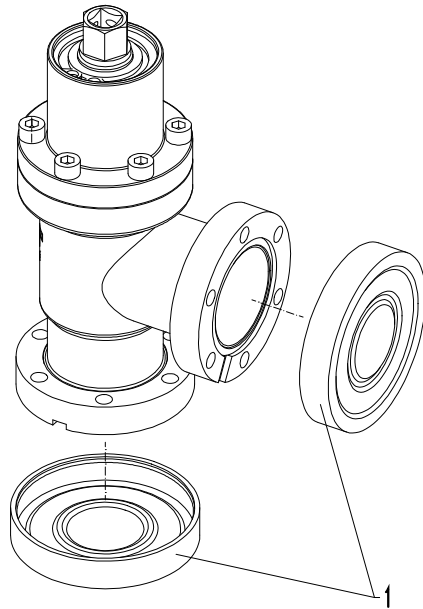

1 Protective covers

Figure 4-1



Store protective covers. They may be useful when valve needs to be repacked.

3. Clean sealing surfaces; see «Figure 3-1» on page 7, with cleanroom wiper soaked with pure alcohol (Isopropanol).
4. Clean sealing surface with clean, oil free compressed air.

#### 4.2.2 Mounting to the system

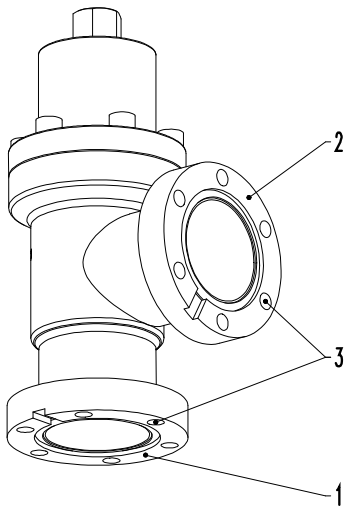

1. Mount valve to your system by using appropriate flange screws (different quantity of screws required – depending on valve size).
2. Mount screws evenly in crosswise order until the seal touches the sealing surface.
3. Tighten all screws with the torques appropriate for the property classes of the screws.



- 1 Flange A (valve seat side)
- 2 Flange B
- 3 Screw holes

Figure 4-2

## 5 Operation

	 <b>WARNING</b>
	<p><b>Unqualified personnel</b> Inappropriate handling may cause serious injury or property damage. Only qualified personnel are allowed to carry out the described work.</p>

### 5.1 Normal operation

Valve is closed and opened manually.

Closing: Turn hexagon head or inner square clockwise to its stop. For moving the plate only a small closing torque is required. Then a second step with a steadily increasing torque (sealing the valve) will follow until the stop is reached.



The sealing force of the valve can't be increased with a higher torque. The force to seal the valve is supplied by a spring, don't overtorque.

Opening: Turn hexagon head counter clockwise to its stop. The valve is completely open when the stop is reached.



If the mechanical stop in open position is reached, no additional torque should be applied. To prevent any damage, the applied torque in fully open position must not exceed **15 Nm**.



For technical details, see product data sheet.

### 5.2 Operation under increased temperature

Maximum allowed temperature see product data sheet.

	<b>NOTICE</b>
	<p><b>Inconstant temperatures</b> Performance of the valve may deteriorate.</p> <ul style="list-style-type: none"> <li>– Actuate valve only after the bake-out temperature has been stable for two hours.</li> <li>– If valve must be actuated during bake-out, make sure that the heating or cooling rate does not exceed 10 °C per hour in the temperature range from 100 °C to 300 °C</li> <li>– Make sure that the temperature differences over the whole body do not exceed 60 °C.</li> </ul>

### 5.3 Trouble shooting

Failure	Check	Action	See
Leak at gate	Condition of gate seal	Please contact VAT	<a href="http://www.vatvalve.com">www.vatvalve.com</a>
	Condition of valve gate	Please contact VAT	<a href="http://www.vatvalve.com">www.vatvalve.com</a>
Leak at body	Condition of bonnet seal and sealing surface	Please contact VAT	<a href="http://www.vatvalve.com">www.vatvalve.com</a>
	Condition of bellows	Please contact VAT	<a href="http://www.vatvalve.com">www.vatvalve.com</a>

Table 5-1

If you need any further information, please contact one of our service centers. You will find the addresses on our website [www.vatvalve.com](http://www.vatvalve.com).

## 6 Maintenance



### 6.1 Maintenance intervals

Under clean operating conditions the valve does not require any maintenance during specified lifetime.



- Impacts from the process may require more frequent maintenance.
- When the valve has reached the specified lifetime; see product data sheet, we recommend to have it serviced by VAT. Please contact your nearest VAT service center to get recommendations and an offer. You will find the addresses on our website [www.vatvalve.com](http://www.vatvalve.com).

## 7 Repairs

	<p style="text-align: center;"><b>WARNING</b></p> <p><b>Unqualified personnel</b> Inappropriate handling may cause serious injury or property damage. Only qualified personnel are allowed to carry out the described work.</p>
	<p style="text-align: center;"><b>WARNING</b></p> <p><b>Danger of injury in case of insufficient skills</b> Inappropriate handling may cause serious injury or property damage. Make sure that the valve does not topple or fall down while removing the protective covers from the flanges.</p>
	<p style="text-align: center;"><b>NOTICE</b></p> <p><b>Contamination</b> Product may get contaminated. Always wear cleanroom gloves when handling the product.</p>



## 7.1 Replacement of dynamic seal – FLEX VATRING

In case of a seat seal leak caused by environmental influences, the FLEX VATRING seal can be replaced twice without the need for re-machining the valve seat.

Three seal rings of different diameters enable leak tight sealing on three different levels of pre-prepared sealing surface provided in the valve body. If there is damage on one level, the replacement seal ring, of a different diameter, will seal at the next level.

VAT offers a range of service kits; see «Table 11-1» on page 25. The seal exchange is easily carried out by the user.

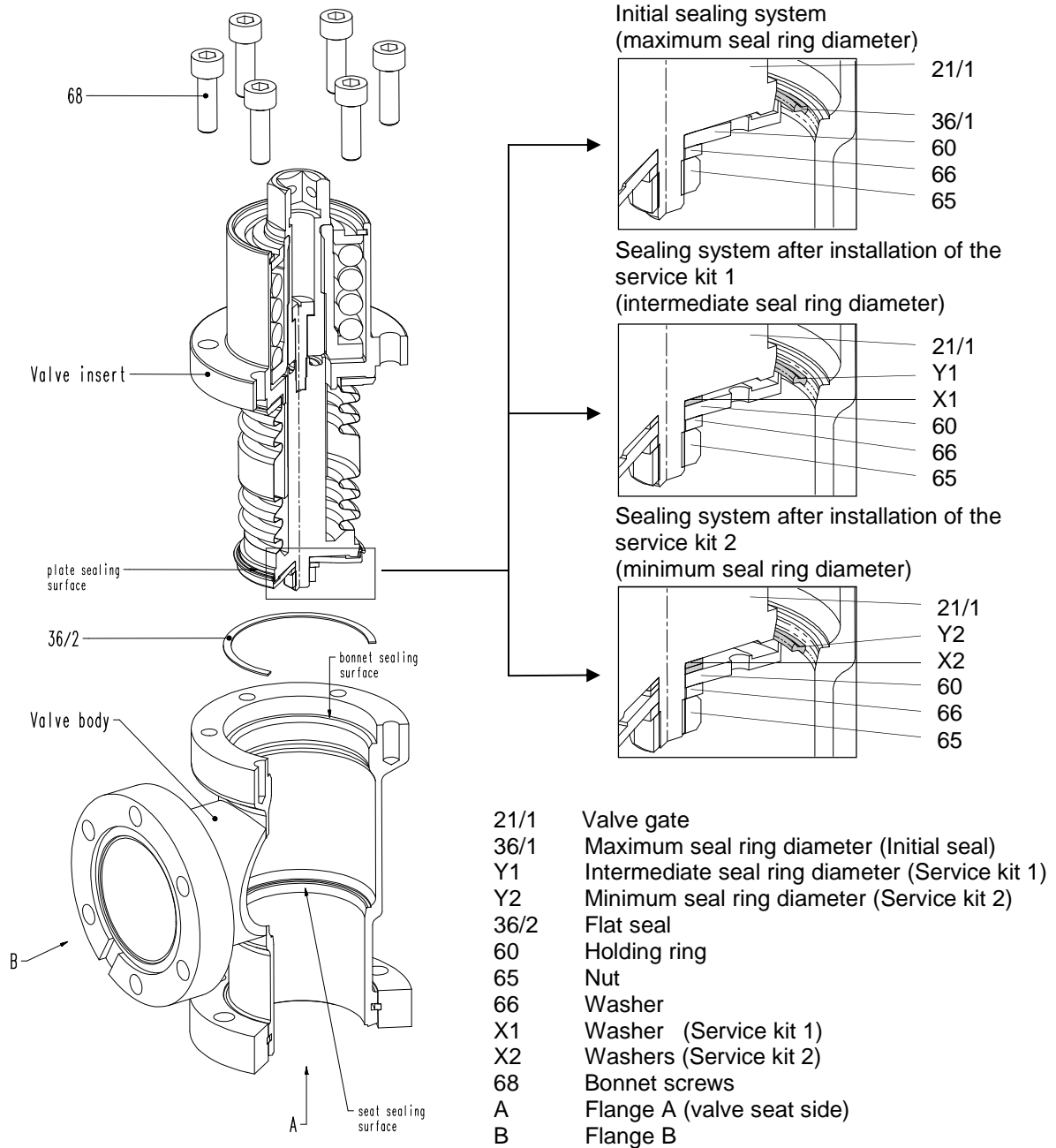



Figure 7-1

Required material: Service kit 1 or 2

Ordering information: See chapter «11 Spare parts» on page 25  
and «Figure 7-1» on page 17

<b>NOTICE</b>	
	<p><b>Inappropriate mounting position of valve</b></p> <p>Maintenance may be troublesome and parts may drop down. Ideally dismount valve from the system and put it on a clean workbench with the actuator upwards.</p>

**Procedure:**

The item numbers in brackets refer to «Figure 7-1» on page 17.

1. Close valve.



Make sure that the valve is closed to mechanical stop! This is required to protect the bellows from twisting and the seal ring from sliding.

2. Loosen the nut (65) but don't remove.
3. Open valve.



Make sure that valve is opened to mechanical stop!

4. Remove bonnet screws (68).
5. Pull valve insert carefully out of the valve body without touching the body wall. Touching the body wall may cause severe damage to delicate parts of the insert.
6. Remove flat seal (36/2).



If you intend to use the flat seal again, please note/mark the bonnet side of the seal. This to be able to use the seal in the same orientation again.

7. Remove the nut (65).
8. Remove washer (66).
9. Remove holding ring (60).
10. Remove FLEX VATRING (36/1).
11. Clean sealing surface of plate (21/1) with pure alcohol (Isopropanol), use a cleanroom wiper.



Make sure that the sealing surface is free of scratches.

12. Put new FLEX VATRING (Y1 or Y2) on sealing surface of plate (21/1).



Make sure that the seal ring is installed in the correct direction. The marks on the ring (see figure 7-2) have to point towards the holding ring and not towards the bellows.

Initial condition FLEX VATRING (36/1) without mark	Service kit 1 FLEX VATRING (Y1) with 1 mark	Service kit 2 FLEX VATRING (Y2) with 2 marks
		

Figure 7-2

13. Put 1 washer (X1) for service kit 1 or 2 washer (X2) for service kit 2 on plate (21/1).

14. Put holding ring (60) on plate (21/1).

15. Put washer (66) on plate (21/1).

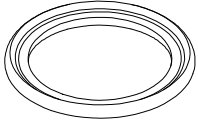
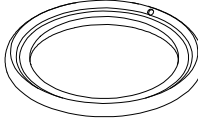
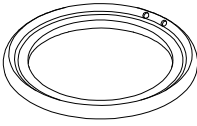
16. Insert nut 65 and tighten the nut slightly. The seal ring, holding ring and washer should only slightly be fixed in their position.

17. Level out FLEX VATRING (Y1 or Y2) and plate (21/1) along the whole circumference. Height difference shall not exceed 0.1 mm. Check height difference accurately at four spots (measured angle 90°) around the whole circumference.

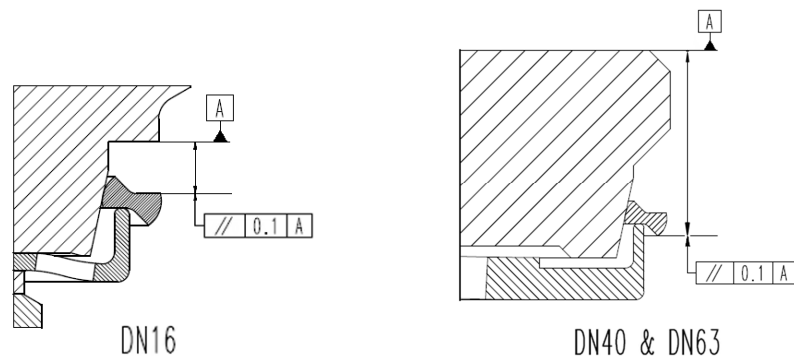

Figure 7-3

18. Clean sealing surfaces of bonnet and seat of valve body with pure alcohol (Isopropanol), use cleanroom wiper.

19. Put the flat seal (36/2) on sealing surface of valve body.



VAT recommends using a new flat seal.

In case of reutilization of the used flat seal please assemble it in the same direction as removed before.

20. Move valve insert (in open position) carefully into body without touching the body wall. Touching the body wall may cause severe damage to delicate parts of the insert.

21. Insert all bonnet screws (68) and screw them in until they touch the bonnet flange (do not tighten).

22. Turn spindle in closing direction until the FLEX VATRING (Y1 or Y2) touches the seal surface to align the valve insert (do not tighten).

23. Tighten all bonnet screws (68) gradually in crosswise order with the following torques:

DN 16: 2.5 Nm

DN 40: 7 Nm

DN 63: 15 Nm

24. Close valve to mechanical stop!

25. Tighten nut (65) with the following torque:

DN 16: 2.5 Nm

DN 40: 7 Nm

DN 63: 15 Nm

Valve is ready for use.

## 8 Dismounting and Storage

	<b>⚠ WARNING</b>
	<p><b>Unqualified personnel</b> Inappropriate handling may cause serious injury or property damage. Only qualified personnel are allowed to carry out the described work.</p>

	<b>NOTICE</b>
	<p><b>Contamination</b> Product may get contaminated. Always wear cleanroom gloves when handling the product.</p>

### 8.1 Dismounting

1. Dismount valve according chapter «4 Installation», however in reverse order.



Observe safety instruction of chapter «4 Installation».

### 8.2 Storage

	<b>NOTICE</b>
	<p><b>Wrong storage</b> Inappropriate temperatures and humidity may cause damage to the product. Valve must be stored at:</p> <ul style="list-style-type: none"> <li>– relative humidity between 10% and 70%</li> <li>– temperature between +10 °C and +50 °C</li> <li>– non-condensing environment</li> </ul>

	<b>NOTICE</b>
	<p><b>Inappropriate packaging</b> Product may get damaged if inappropriate packaging material is used. Always use the original packaging material and handle product with care.</p>

1. Clean / decontaminate valve.
2. Cover all valve openings with a protective foil.
3. Pack valve appropriately, by using the original packaging material.

## 9 Packaging and Transport

	<p style="text-align: center;"><b>⚠ WARNING</b></p> <p><b>Unqualified personnel</b>                  Inappropriate handling may cause serious injury or property damage.                  Only qualified personnel are allowed to carry out the described work.</p>
	<p style="text-align: center;"><b>⚠ WARNING</b></p> <p><b>Harmful substances</b>                  Risk of injury in case of contact with harmful substances.                  Remove harmful substances (e. g. toxic, caustic or microbiological ones) from valve before you return the valve to VAT.</p>
	<p style="text-align: center;"><b>NOTICE</b></p> <p><b>Inappropriate packaging</b>                  Product may get damaged if inappropriate packaging material is used.                  Always use the original packaging material and handle product with care.</p>



- When returning products to VAT, please fill out the VAT form «Declaration of Chemical Contamination» and send it to VAT in advance. The form can be downloaded from our website [www.vatvalve.com](http://www.vatvalve.com).
- If products are radioactively contaminated, the VAT form «Contamination and Radiation Report» must be filled out. Please contact VAT in advance.
- If products are sent to VAT in contaminated condition, VAT will carry out the decontamination procedure at the customer's expense.

## 9.1 Packaging

1. Cover all valve openings with protective covers; see chapter «4.2.1 Preparation for installation».
2. Pack valve appropriately, by using the original packaging material.



VAT disclaims any liability for damages resulting from inappropriate packaging.

## 9.2 Transport



### **NOTICE**

#### **Inappropriate packaging**

Product may get damaged if inappropriate packaging material is used.  
Always use the original packaging material and handle product with care.



VAT disclaims any liability for damages resulting from inappropriate packaging.

## 10 Disposal

	<b>⚠ WARNING</b>	
	<b>Harmful substances</b>	

Environmental pollution.  
Discard products and parts according to the local regulations.



## 11 Spare parts

<b>NOTICE</b>	
	<p><b>Non-original spare parts</b> Non-original spare parts may cause damage to the product. Use original spare parts from VAT only.</p>



- Please specify the fabrication number of the product when you place an order for spare parts; see chapter «1.1 Identification of product». This is to ensure that the appropriate spare parts are supplied.
- VAT makes a difference between spare parts that may be replaced by the customer and those that need to be replaced by the VAT service staff.
- «Table 11-1» only contains spare parts that may be replaced by the customer. If you need any other spare parts, please contact one of our service centers. You will find the addresses on our website [www.vatvalve.com](http://www.vatvalve.com).

Description	Item	DN	Part No.	Quantity per valve	Repair procedure see chapter
Service kit 1 consisting of FLEX VATRING (X1) and 1 washer (Y1)		16	529581	1	«7.1 Replacement of dynamic seal – FLEX VATRING»
		40	530022	1	
		63	530024	1	
Service kit 2 consisting of FLEX VATRING (X2) and 2 washers (Y2)		16	529582	1	
		40	530023	1	
		63	530025	1	
Flat seal	36/2	16	240288	1	
		40	320744	1	
		63	241684	1	
Bonnet screws	68	16	236055	6	
		40	218189	6	
		63	224828	8	

Table 11-1